

A **Unique** Solution for **Individual DDI recovery** - including the Option for full Call Recording of all re-routed calls

Solution Currently Available from the Carriers

Your Carrier (BT?) can re-route all incoming calls to one alternative number within the same local exchange area and take the full DDI information with the divert

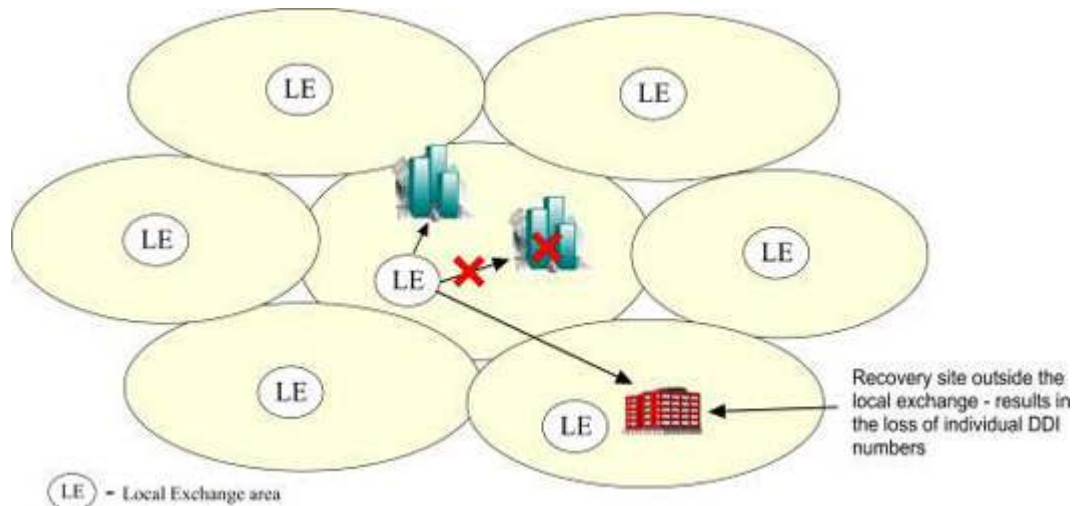

GemaTech's Unique Enhanced Solution

GemaTech's BCM^{LITE} can instantaneously re-route any number of individual DDIs to any number of alternative numbers (land lines, mobiles, satellite phones including individual fax number to individual fax number)

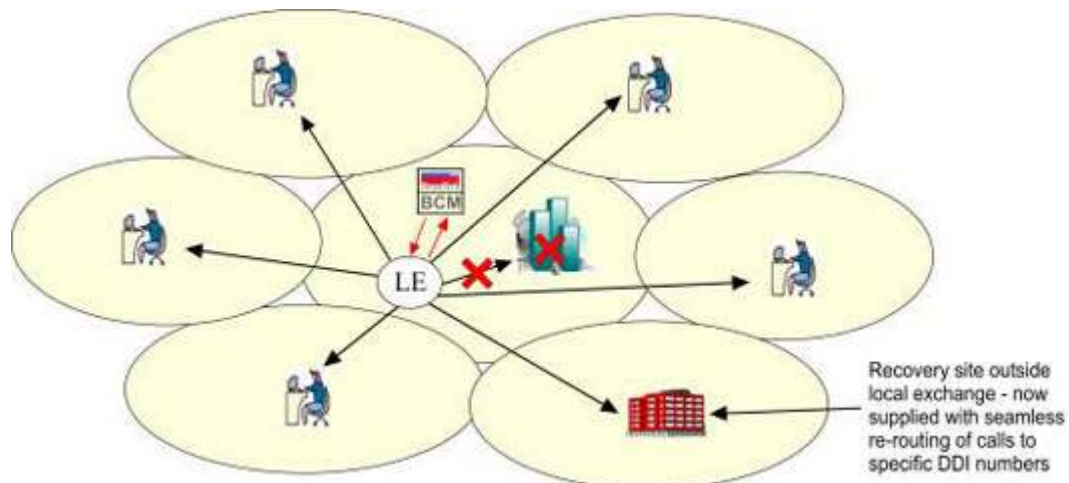

“GemaTech - Taking the solution to your Employees rather than dragging your Employees to the solution”

A **Unique** Solution for **Individual DDI recovery** - including the Option for full Call Recording of all re-routed calls

Prior to an incident being declared: BCM^{LITE} OPTION I in “dormant mode” in the serving carrier’s (BT, COLT, ntl etc) “local” exchange

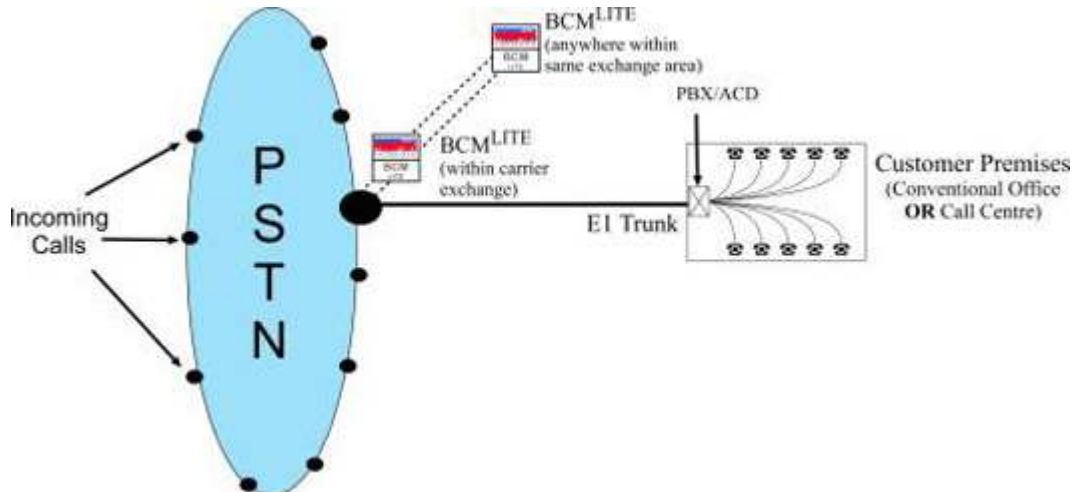

Immediately following an invocation: Calls can be instantaneously re-routed to the BCM^{LITE} unit with calls being re-routed on an individual DDI basis to any other number – all in accordance with any one of up to 100 different call plans – which can be quickly and easily activated by the end user from a remote PC or PDA

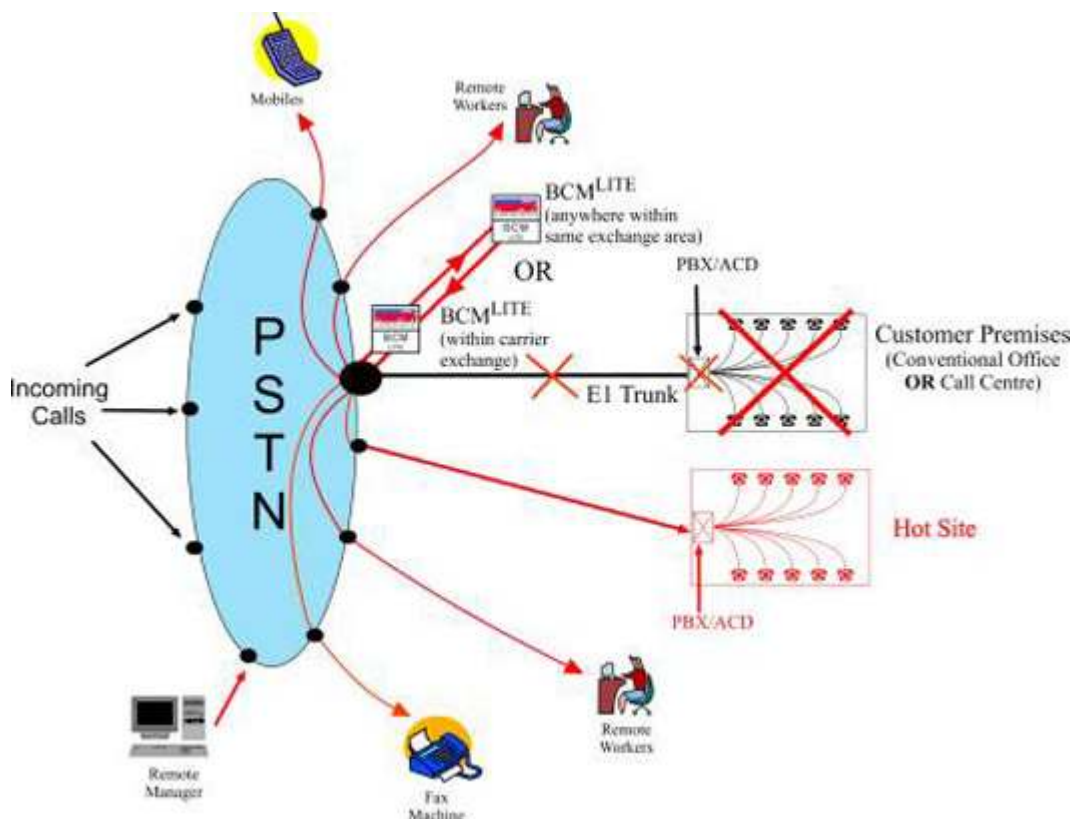

Note: With this solution all calls can be recorded immediately after an invocation using GemaTech's unique Secure Voice Recording module, SVR^{LITE}

A Unique Solution for Individual DDI recovery - including the Option for full Call Recording of all re-routed calls

Prior to an incident being declared: BCM^{LITE} OPTION II seamlessly passes through incoming/outgoing calls to/from receiving/issuing DDIs

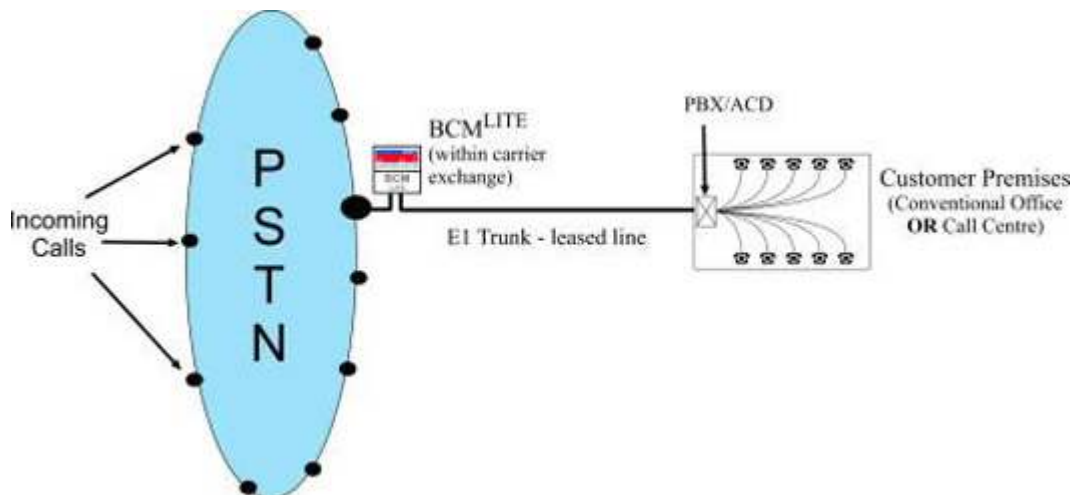

Immediately following an Invocation: Selected calls can be re-routed back out to the PSTN via a dialled up connection to alternative individual numbers while others (in a partial invocation) can be seamlessly passed through to the original recipient – in accordance with any one of up to 100 different call plans – which can be quickly and easily activated by the end user from a remote PC or PDA

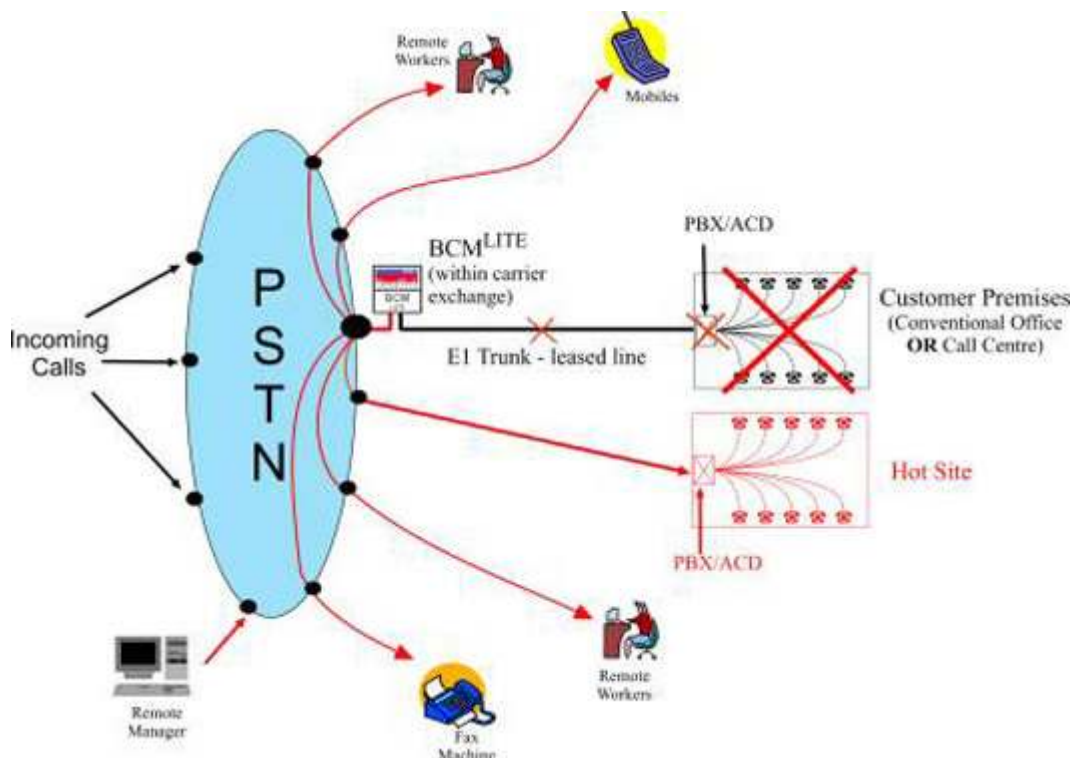

Note: With this solution all calls can be recorded both before and immediately after an invocation using GemaTech's unique Secure Voice Recording module, SVR^{LITE}